

märklin

Z

Modell der Diesellok ER 20

81881

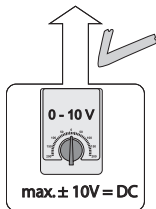

max. $\pm 10V = DC$

67011
67020 + 67030
67201
67271

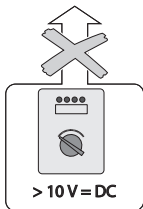

$> 10V = DC$

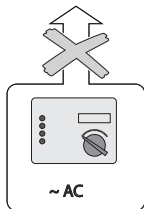

$\sim AC$

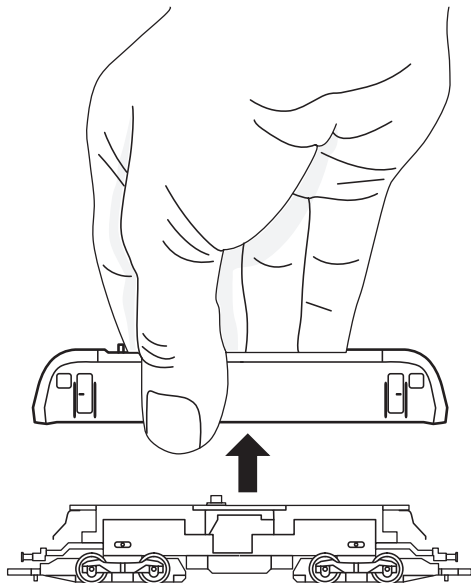

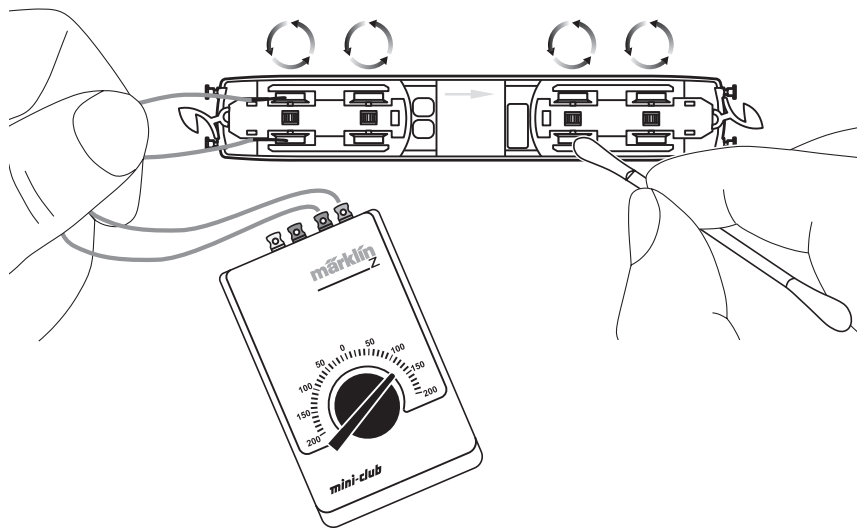

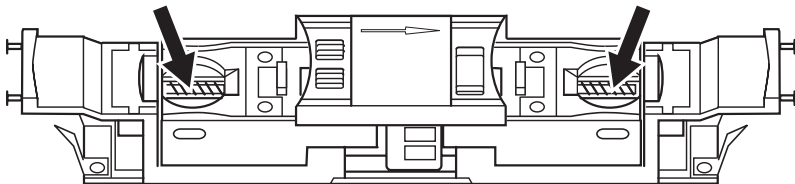
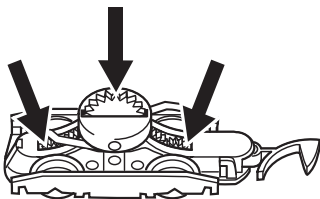
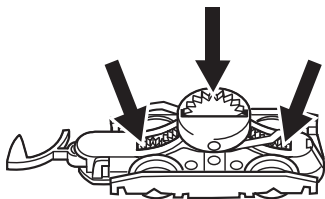
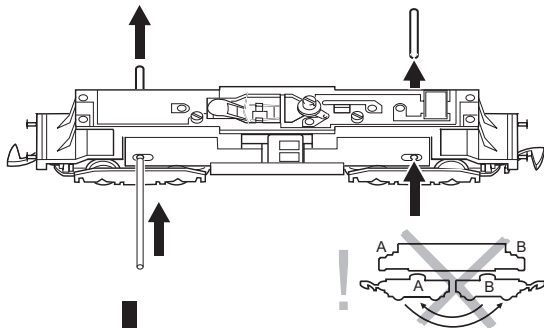
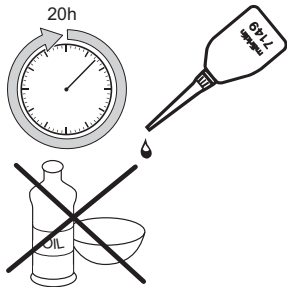

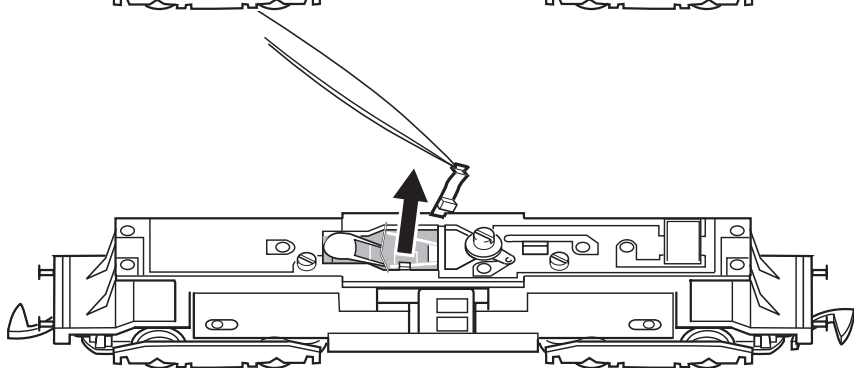
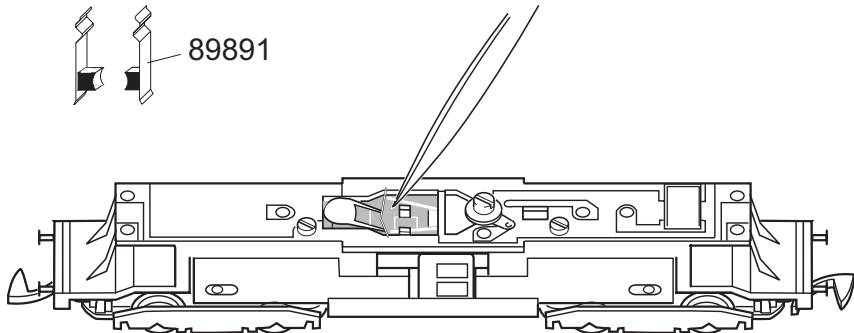
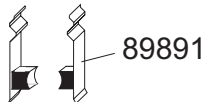

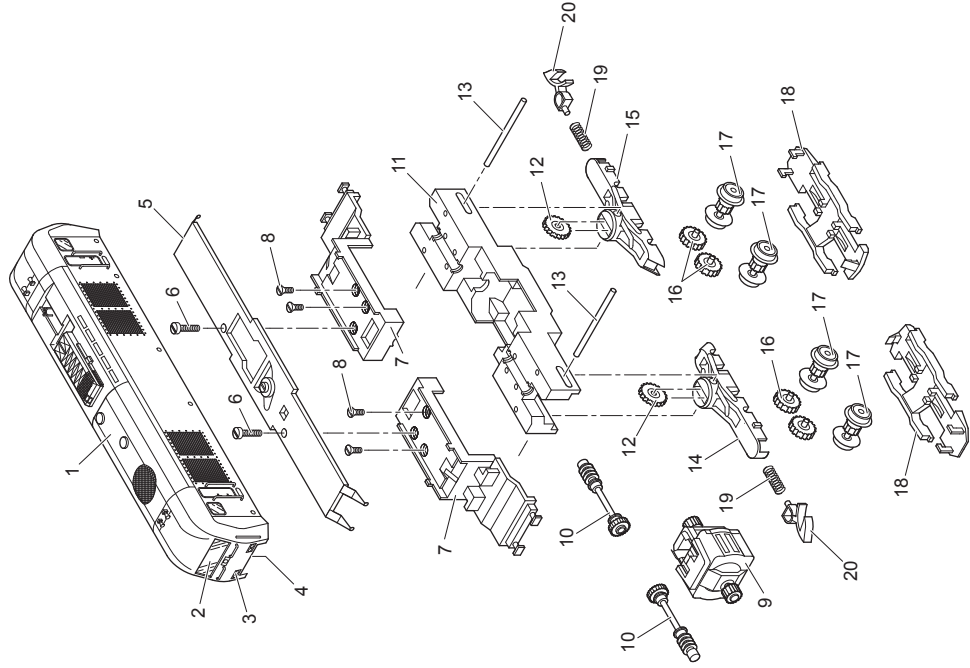

1	Aufbau	134 050
2	Fenstereinsatz	117 038
3	Beleuchtungseinheit	116 993
4	Lichtabdeckung	116 992
5	Leiterplatte	485 660
6	Zylinderschraube	785 190
7	Isolierung	116 985
8	Senkschraube	785 550
9	Motor	211 903
10	Antriebswelle	265 250
11	Rahmen	116 997
12	Zahnrad	262 960
13	Achse	260 720
14	Getriebegehäuse vorn	218 315
15	Getriebegehäuse hinten	218 317
16	Zwischenradsatz	260 920
17	Treibradsatz	216 476
18	Drehgestellrahmen	116 999
19	Druckfeder	765 680
20	Kupplungshaken	704 200

Gebr. Märklin & Cie. GmbH
Postfach 860
D-73008 Göppingen
www.maerklin.com

134079/0608/SmSk
Änderungen vorbehalten
© Gebr. Märklin & Cie. GmbH