

**märklin**  
Z

---

Modell der

**BR 101**

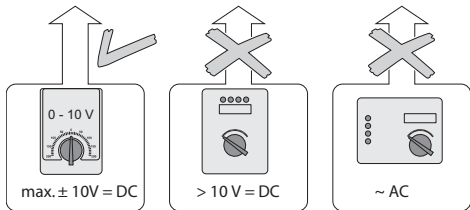

max. ± 10V = DC

> 10V = DC

~ AC

67011  
67020 + 67030  
67201  
67271

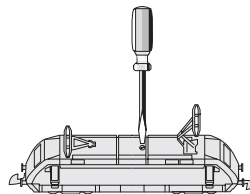
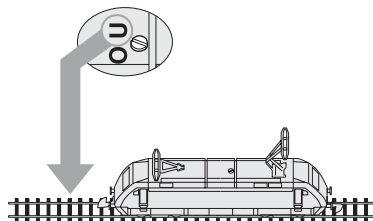

Bei Oberleitungsbetrieb Pfeil beachten!

To operate the catenary system follow the direction indicated by the arrow.

Pour utilisation de la caténaire tenir compte de la flèche.

Bij gebruik van bovenleiding op pijl letten!

Al funcionar con catenaria obsérvese la flecha.

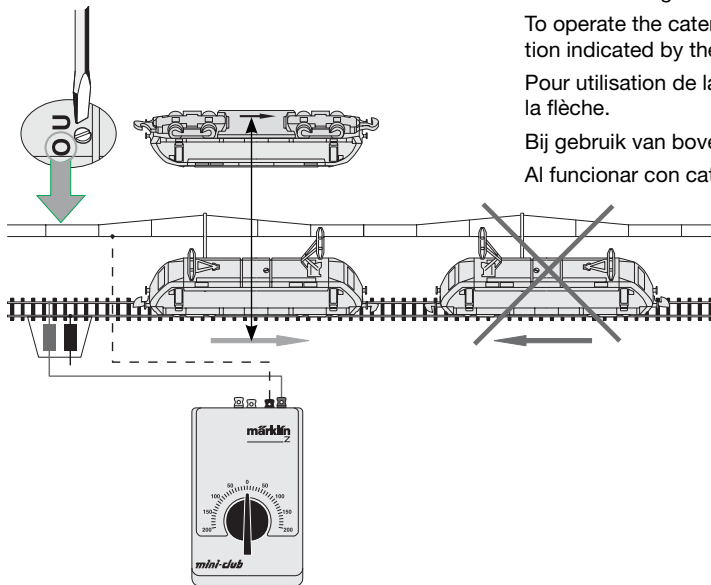

Per esercizio tramite la catenaria osservare la freccia.

Vid kontaktledningsdrift observera pilen.

Ved luftledningsdrift, bemærk pil.

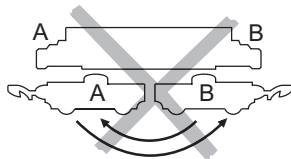
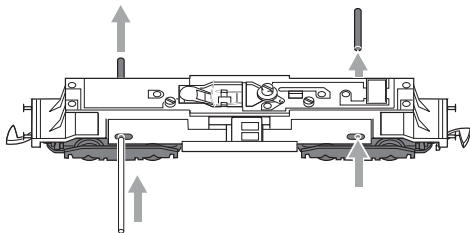
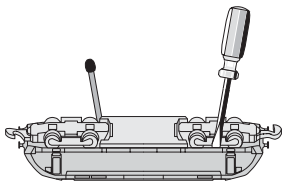
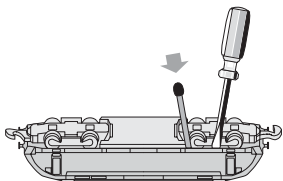
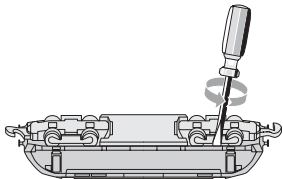

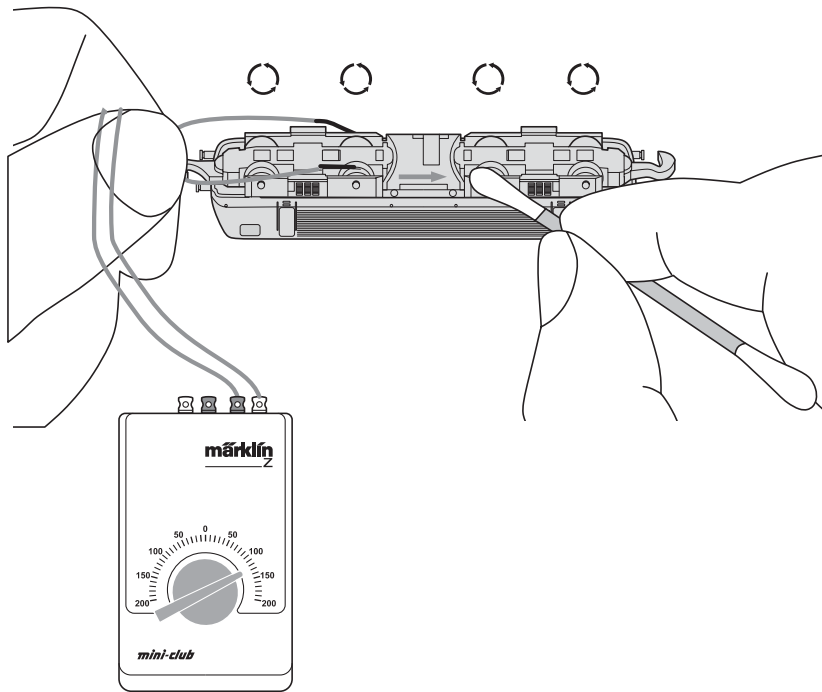

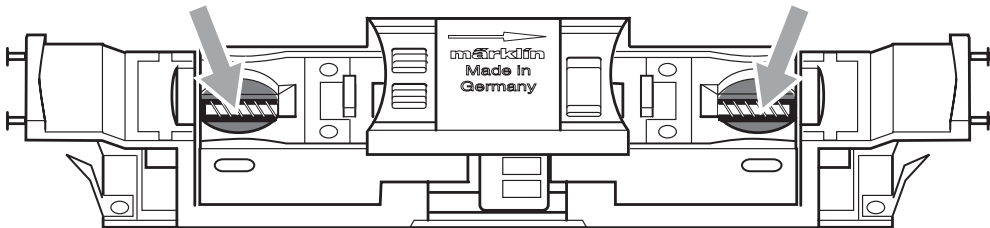
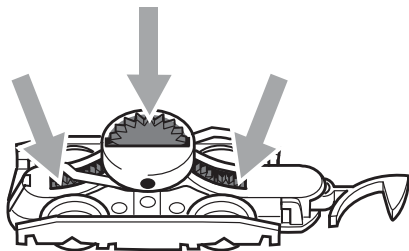
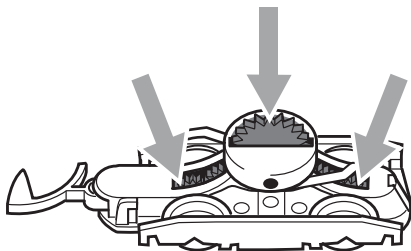
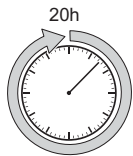

### **Wichtige Hinweise zum Ölen der Motorlager**

- Nur sparsam ölen (max. 1 Tropfen). Zuviel Öl führt

häufig zum Verschmieren der Kollektoren und damit zur Beschädigung des Ankers.

- Nach dem Aufbringen des Öltropfens auf das Motor-Lager den Anker bewegen. Anschließend überschüssiges Öl mit einem trockenen Tuch entfernen.

### **Important Information about Oiling the Motor Bearings**

- Oil sparingly (max. 1 drop). Too much oil frequently causes the commutator to become dirty and thereby leads to damage to the armature.
- After you have placed a drop of oil on the motor bearings, move the armature back and forth a little. Now remove the excess oil with a dry cloth.

### **Remarque importante au sujet de la lubrification des paliers du moteur**

- Lubrifiez en très petite quantité (1 goutte max.). Trop d'huile entraîne souvent l'encrassement du collecteur et à des dommages à l'induit.
- Une fois la goutte d'huile déposée sur le palier de moteur, faites tourner l'induit. Ensuite, essuyez le surplus d'huile à l'aide d'un chiffon sec.

### **Belangrijke opmerking voor het oliën van het motorlager**

- Slechts spaarzaam oliën (max. 1 druppel). Te veel olie leidt vaak tot versmeren van de collector en daarmee tot beschadiging van het anker.
- Na het aanbrengen van de oliedruppel op het motorlager het anker ronddraaien. Aansluitend met een droge doek de overvloedige olie verwijderen.

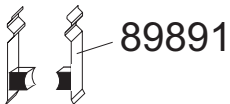

89891

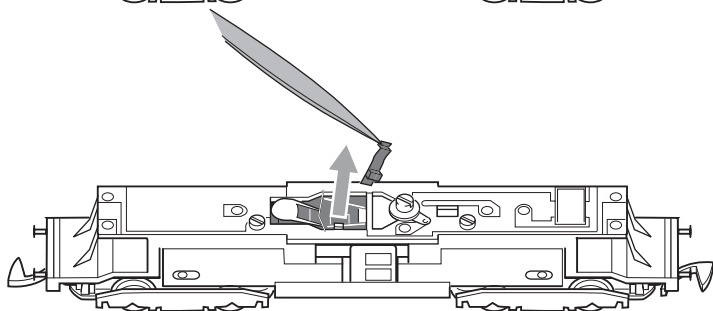
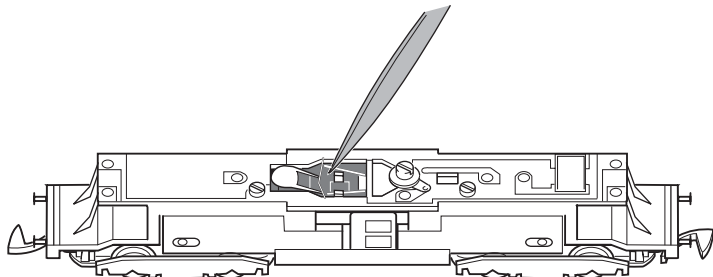

Gebr. Märklin & Cie. GmbH  
Postfach 860  
D-73008 Göppingen  
[www.maerklin.com](http://www.maerklin.com)



604966/1204/SmEf  
Änderungen vorbehalten  
© Gebr. Märklin & Cie. GmbH