

max.  $\pm 10V = DC$

67011  
67020 + 67030  
67201  
67271

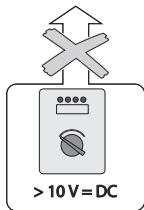

> 10V = DC

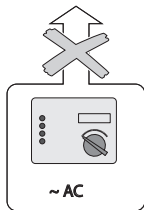

~ AC

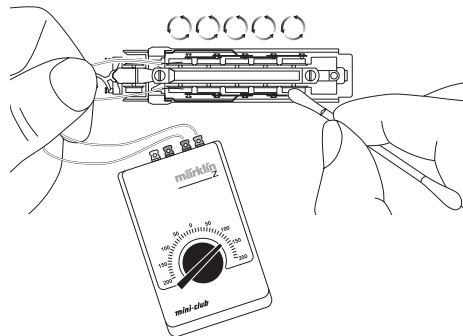

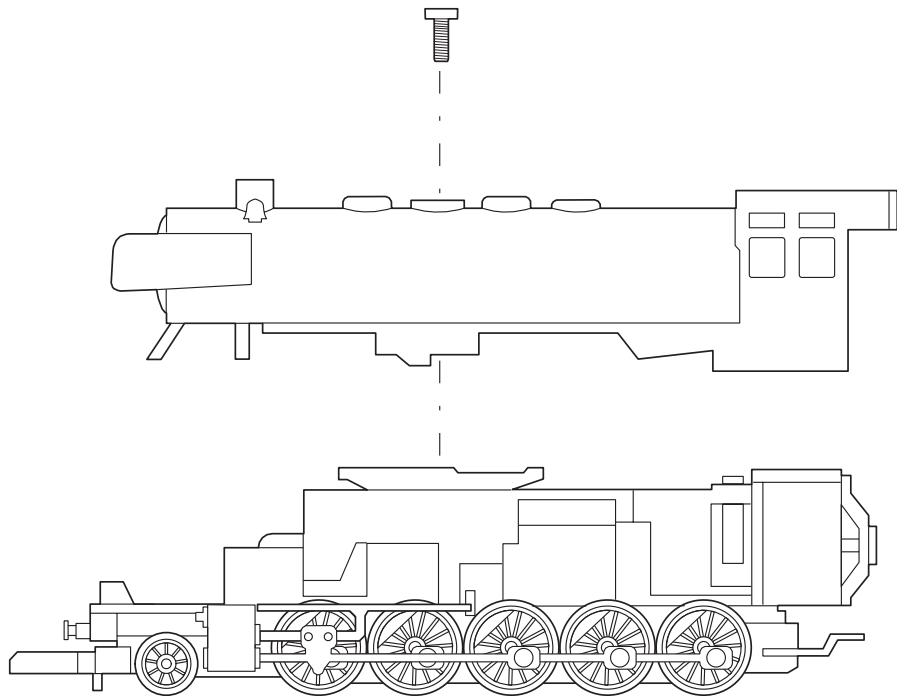

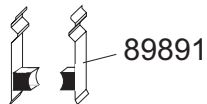
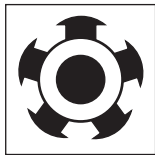

8953

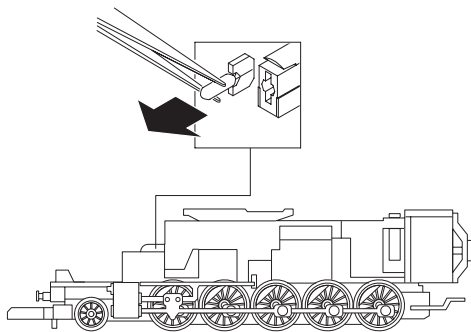
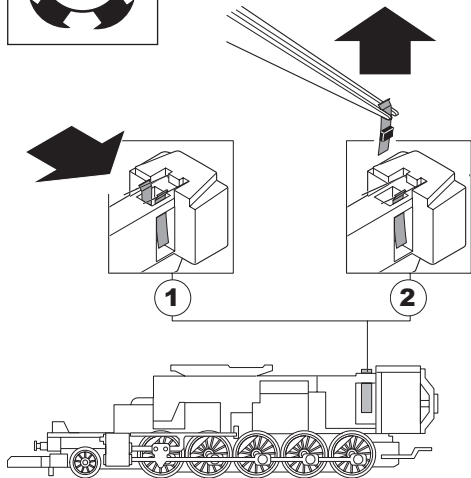

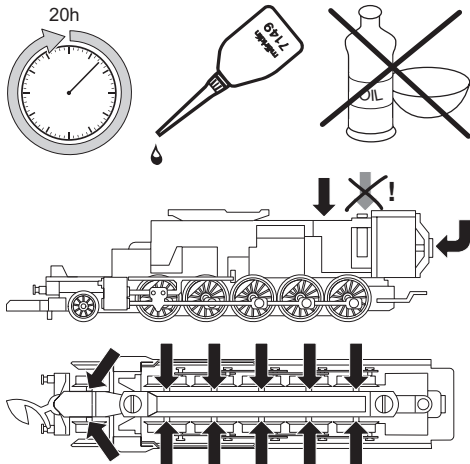

- Nur sparsam ölen (max. 1 Tropfen). Zuviel Öl führt häufig zum Verschmieren der Kollektoren und damit zur Beschädigung des Ankers.
- Oil sparingly (max. 1 drop). Too much oil frequently causes the commutator to become dirty and thereby leads to damage to the armature.
- Lubrifiez en très petite quantité (1 goutte max.). Trop d'huile entraîne souvent l'encrassement du collecteur et à des dommages à l'induit.
- Slechts spaarzaam oliën (max. 1 druppel). Te veel olie leidt vaak tot versmeren van de collector en daarmee tot beschadiging van het anker.

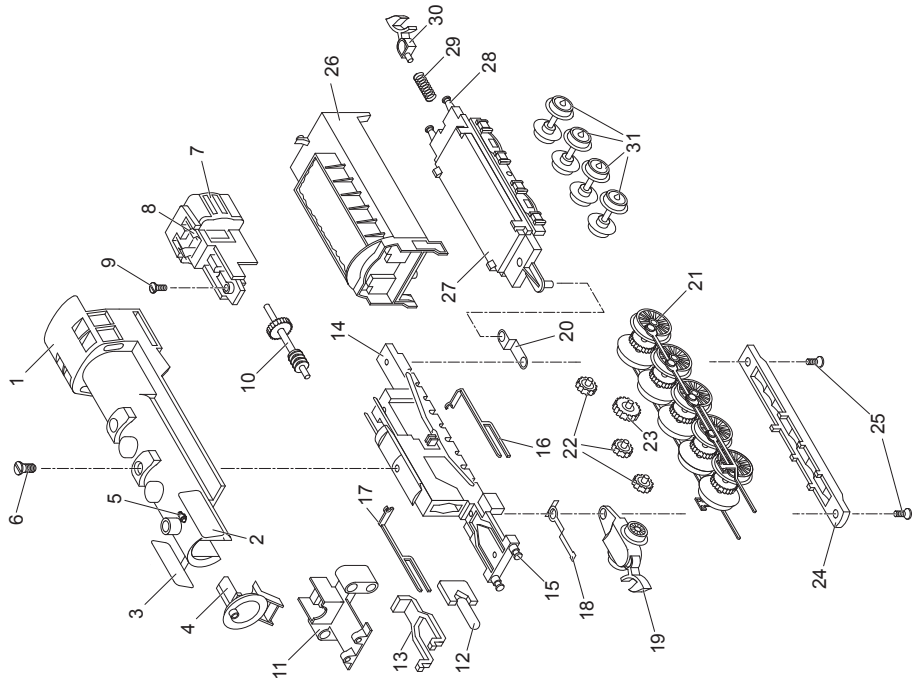

1	Aufbau komplett	120 836	26	Aufbau	120 839
2	Windleitblech links	120 824	27	Boden	261 440
3	Windleitblech rechts	120 825	28	Puffer	761 450
4	Leuchtstab	120 826	29	Druckfeder	765 680
5	Lichtmaschiene	264 850	30	Kupplungshaken	704 200
6	Senkschraube	756 100	31	Radsatz	215 721
7	Motor komplett	211 915			
8	Motorbürsten	89 891			
9	Senkschraube	785 550			
10	Antriebswelle	226 940			
11	Zylinderblock	267 380			
12	Beleuchtungseinheit	8 953			
13	Lichtkörper	267 390			
14	Traggestell	120 829			
15	Puffer	761 480			
16	Kreuzkopfführung links	216 121			
17	Kreuzkopfführung rechts	216 119			
18	Feder	264 890			
19	Laufgestell	225 624			
20	Kuppelblech	267 330			
21	Treibradsatz	216 122			
22	Zwischenradsatz	267 310			
23	Zwischenradsatz	267 320			
24	Abdeckung	267 300			
25	Senkschraube	785 550			

Gebr. Märklin & Cie. GmbH  
Postfach 860  
D-73008 Göppingen  
[www.maerklin.com](http://www.maerklin.com)

120840/0608/SmSk  
Änderungen vorbehalten  
© Gebr. Märklin & Cie. GmbH