

**märklin**  
Z

Modell der

**Serie A3/5**

---

**81035**

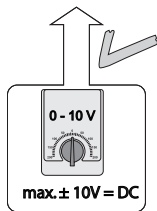

max.  $\pm 10V = DC$

67011  
67020 + 67030  
67201  
67271

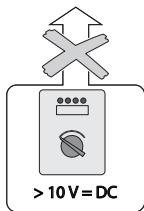

$> 10V = DC$

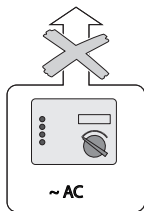

$\sim AC$

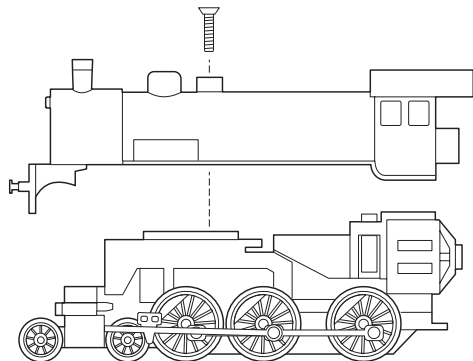

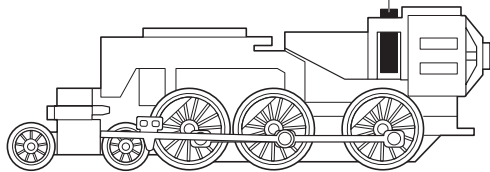
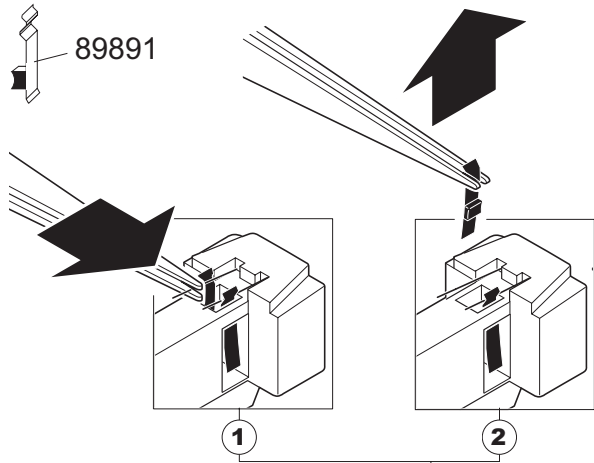
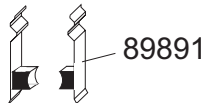

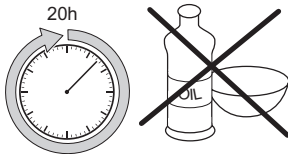

- Nur sparsam ölen (max. 1 Tropfen). Zuviel Öl führt häufig zum Verschmieren der Kollektoren und damit zur Beschädigung des Ankers.
- Oil sparingly (max. 1 drop). Too much oil frequently causes the commutator to become dirty and thereby leads to damage to the armature.
- Lubrifiez en très petite quantité (1 goutte max.). Trop d'huile entraîne souvent l'encrassement du collecteur et à des dommages à l'induit.
- Slechts spaarzaam oliën (max. 1 druppel). Te veel olie leidt vaak tot versmeren van de collector en daarmee tot beschadiging van het anker.

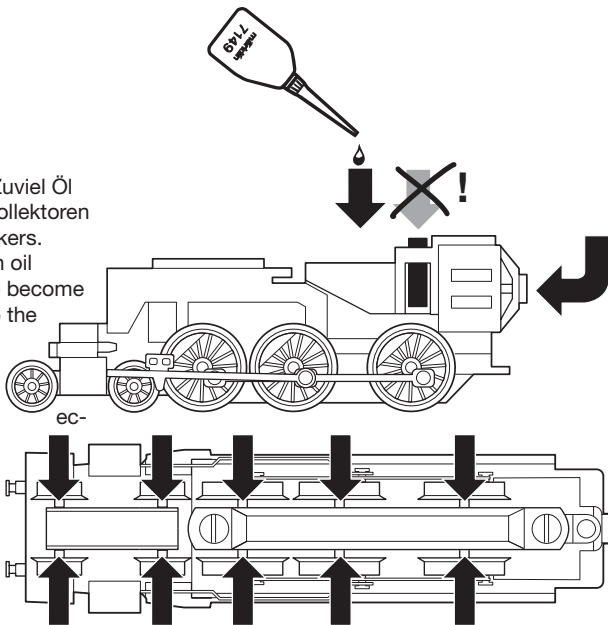

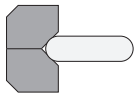

8953

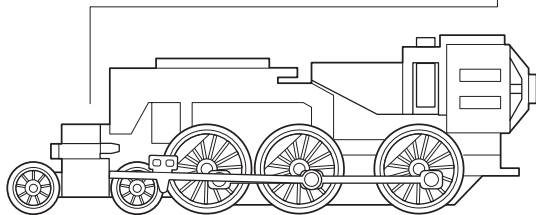
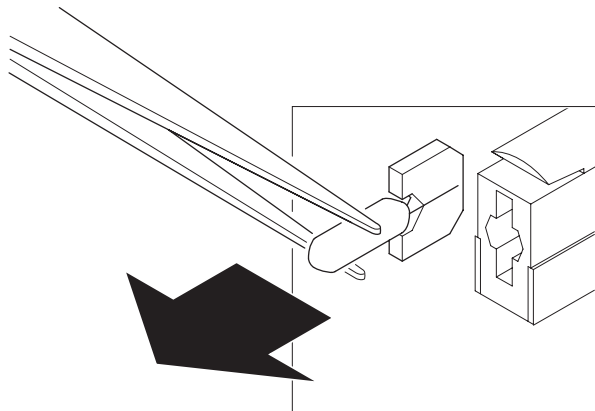

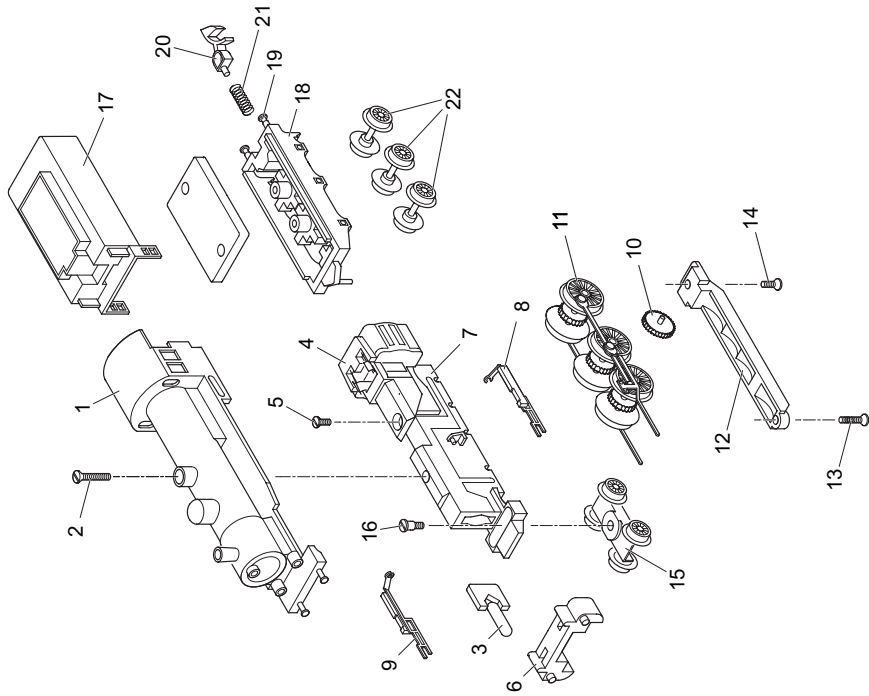

1	Aufbau komplett	108 947
2	Senkschraube	756 090
3	Beleuchtungseinsatz	8 953
4	Motor	211 912
5	Senkschraube	785 550
6	Zylinderblock	266 000
7	Traggestell	108 475
8	Kreuzkopfführung links	106 368
9	Kreuzkopfführung rechts	106 365
10	Zwischenradsatz	265 930
11	Treibradsätze mit Gestänge	106 393
12	Abdeckung	266 010
13	Senkschraube	785 570
14	Senkschraube	785 580
15	Drehgestell	221 158
16	Zylinderansatzschraube	753 130
	Tender	
17	Tendergehäuse	110 128
18	Tenderboden	326 848
19	Puffer	761 450
20	Kupplungshaken	704 200
21	Druckfeder	765 680
22	Radsatz	215 721

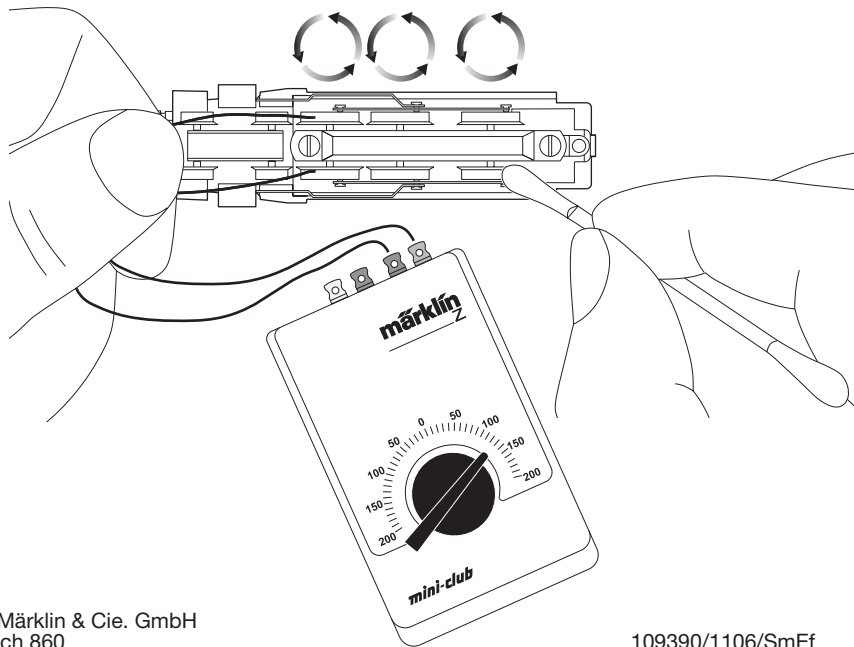

Gebr. Märklin & Cie. GmbH  
Postfach 860  
D-73008 Göppingen  
[www.maerklin.com](http://www.maerklin.com)

109390/1106/SmEf  
Änderungen vorbehalten  
© Gebr. Märklin & Cie. GmbH